

AUTUMN RIDGE

LOCATED IN THE SW1/4 OF THE NE1/4 OF SECTION 13, TOWNSHIP 5 NORTH, RANGE 9 EAST, VILLAGE OF OREGON, DANE COUNTY, WISCONSIN

There are no objections to this plat with respect to Sees. 236.15, 236.16, 236.20 and 236.21(1) and (2), Wis. Stats. as provided by s. 236.12, Wis. Stats.

Certified _____, 20__



Department of Administration



CURVE TABLE

CURVE NUMBER	LOT	RADIUS (FEET)	CHORD BEARING	CHORD (FEET)	ARC (FEET)	CENTRAL ANGLE
1	1	233.00	N45°54'13"E	329.51	366.00	90°00'00"
	2	233.00	N02°59'44"E	17.01	17.01	04°11'02"
	DL 1	233.00	N13°35'49"E	68.96	69.21	17°01'08"
	3	233.00	N44°25'00"E	176.90	181.45	44°37'14"
	4	233.00	N76°06'23"E	75.94	76.29	18°45'32"
	DL 2	167.00	N45°54'13"E	236.17	262.32	90°00'00"
	DL 3	167.00	N09°04'36"E	47.48	47.64	16°20'46"
	DL 4	167.00	N40°49'59"E	133.63	137.48	47°10'00"
	DL 5	167.00	N67°50'57"E	20.00	20.01	06°51'56"
	DL 6	167.00	N79°53'30"E	50.00	50.19	17°13'10"
	DL 7	167.00	N89°42'09"E	7.00	7.00	02°24'08"
2	15	15.00	S45°24'49.5"W	21.39	23.82	90°58'47"
3	15	15.00	S44°35'10.5"E	21.03	23.31	89°01'13"

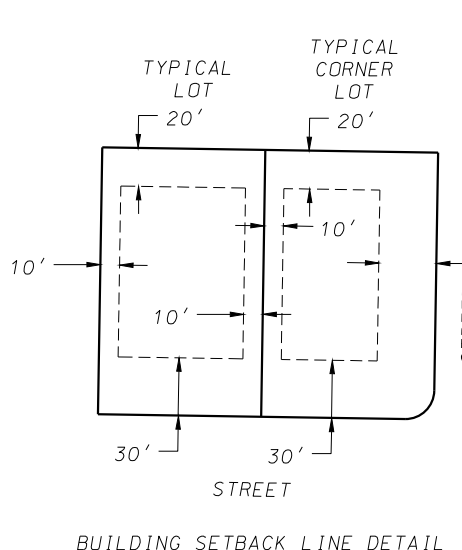
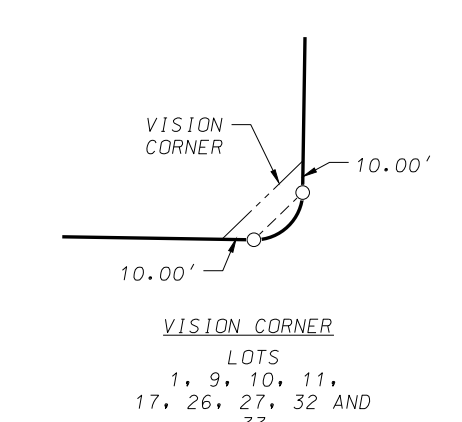

LINE TABLE

L1	=	S22°32'40"E	10.00'
L2	=	S67°50'57"W	20.00'
L3	=	N22°32'40"W	10.00'

- LEGEND**
- Placed 1-1/4" x 18" solid round iron rebar stake, weighing 4.30 lbs/ft. All other lot and outlier corners are marked with 3/4" x 18" solid round iron rebar stakes, weighing 1.50 lbs/ft.
 - Found 1" Iron Pipe
 - Found 1-1/4" Iron Rebar
 - Found 3/4" Iron Rebar

Public utility easement
Utility easements as herein set forth are for the use of PUBLIC BODIES and PRIVATE PUBLIC UTILITIES having the right to serve the area.

Recorded as information

- NOTES**
- No structures, retaining walls, or grading allowed within the Stormwater Drainage Easements shown on this plat.
 - Outlot 3 is to be owned and maintained by the Autumn Ridge Neighborhood Association and be used for group mailbox purposes.

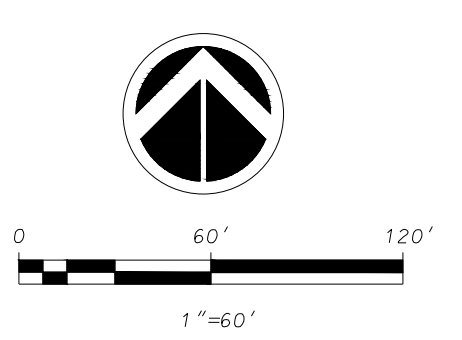
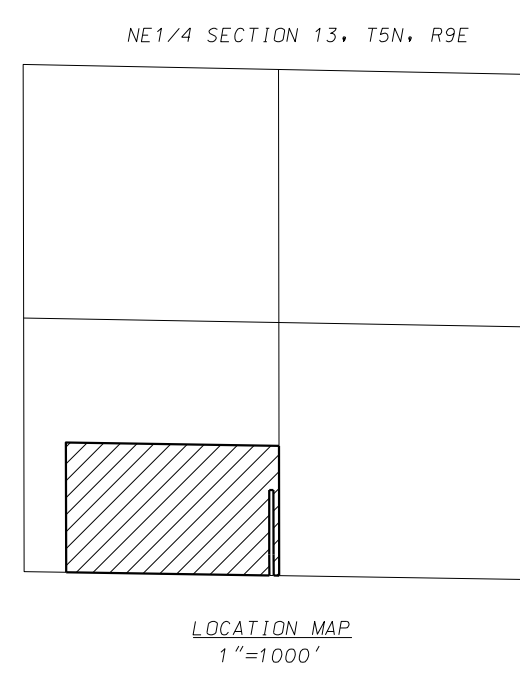
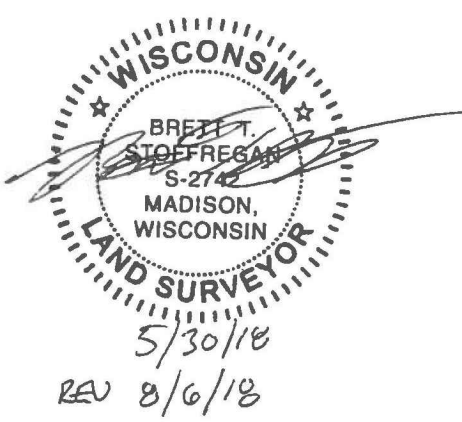

BEARINGS REFERENCED TO THE SOUTH LINE OF THE NORTHEAST QUARTER OF SECTION 13, T5N, R9E WISCONSIN COUNTY COORDINATE SYSTEM (DANE ZONE) BEARING N89°05'47"W

D'ONOFRIO KOTTKE AND ASSOCIATES, INC.
7530 Westward Way, Madison, WI 53717
Phone: 608.833.7530 • Fax: 608.833.1089
YOUR NATURAL RESOURCE FOR LAND DEVELOPMENT

FN:17-07-120

AUTUMN RIDGE

LOCATED IN THE SW1/4 OF THE NE1/4 OF SECTION 13, TOWNSHIP 5 NORTH, RANGE 9 EAST, VILLAGE OF OREGON, DANE COUNTY, WISCONSIN

There are no objections to this plat with respect to Secs. 236.15, 236.16, 236.20 and 236.21(1) and (2), Wis. Stats. as provided by s. 236.12, Wis. Stats.

Certified _____, 20____



Department of Administration

SURVEYOR'S CERTIFICATE

I, Brett T. Stoffregan, Professional Land Surveyor, S-2742, do hereby certify that this plat is in full compliance with Chapter 236 of the Wisconsin Statutes and the Subdivision Regulations of the Village of Oregon, Dane County, Wisconsin and under the direction of the Owners listed below, I have surveyed, divided and mapped the land described herein and that said plat is a correct representation of the exterior boundaries of the land surveyed and the division thereof. Said land is described as follows:

A parcel of land located in the SW1/4 of the NE1/4 of Section 13, T5N, R9E, Town of Oregon, Dane County, Wisconsin to-wit: Commencing at the East 1/4 corner of said Section 13: thence N89°05'47"W, 1327.70 feet along the South line of said NE1/4 to the Southeast corner of said SW1/4, also being the point of beginning; thence N89°05'47"W, 28.34 feet along said South line; thence N00°19'45"W, 109.47 feet; thence N00°04'34"W, 335.67 feet; thence S89°55'26"W, 22.00 feet; thence S00°04'34"E, 335.72 feet; thence S00°19'45"E, 109.04 feet to said South line; thence N89°05'47"W, 1058.13 feet along said South line to the Southeast corner of Autumn Woods Fairway Estates Second Addition; thence N00°07'30"W, 675.07 feet along the East line of Autumn Woods Fairway Estates Second Addition; thence S89°05'53"E, 1109.06 feet along the South line of Lot 59, Autumn Woods Fairway Estates Second Addition and the South line of Autumn Woods Fairway Estates Third Addition to a point on the East line of said SW1/4; thence S00°04'31"E, 675.10 feet along the East line of said SW1/4 to the point of beginning. Containing 738,608 square feet (16.956 acres).

Dated this 30th day of May, 2018.
Revised this 6th day of August, 2018.

Brett T. Stoffregan, Professional Land Surveyor, S-2742



OWNER'S CERTIFICATE

As Owners, we hereby certify that we caused the land described on this plat to be surveyed, divided, mapped and dedicated as represented on the plat. We also certify that this plat is required by S236.10 or S236.12 Wisconsin Statutes to be submitted to the following agencies for approval or objection:

Department of Administration
Village Board, Village of Oregon
Dane County Zoning and Land Regulation Committee

Witness the hand and seal of said owners this _____ day of _____, 2018.

Glenn and Michelle Hofer Living Trust

Glenn Hofer

Michelle Hofer

STATE OF WISCONSIN)
COUNTY OF DANE) S.S

Personally came before me this _____ day of _____, 2018, the above named Glenn Hofer and Michelle Hofer to me known to be the person(s) who executed the foregoing instrument and acknowledged the same.

Notary Public, Dane County, Wisconsin
My commission expires _____

VILLAGE BOARD RESOLUTION

I, Peggy Haag, being duly appointed, qualified and acting Clerk of the Village of Oregon, Dane County, do hereby certify that the Village Board of the Village of Oregon has authorized me to issue a certificate of approval of the final plat "Autumn Ridge", upon satisfaction of certain conditions and I do hereby certify that all conditions were satisfied and the approval was granted and effective on the _____ day of _____, 2018.

Peggy Haag, Clerk, Village of Oregon, Dane County

Date: _____

VILLAGE TREASURER'S CERTIFICATE

I, Lisa Novinska, being the duly appointed, qualified, and acting Treasurer of the Village of Oregon, Dane County, do hereby certify that, in accordance with the records in my office, there are no unpaid taxes or unpaid special assessments as of this _____ day of _____, 2018 on any of the lands included in the plat of "Autumn Ridge".

Lisa Novinska, Treasurer, Village of Oregon, Dane County

COUNTY TREASURER'S CERTIFICATE

I, Adam Gallagher, being the duly elected, qualified, and acting treasurer of the County of Dane, do hereby certify that in accordance with the records in my office, there are no unpaid taxes or special assessments as of this _____ day of _____, 2018 affecting the land included in "Autumn Ridge".

Adam Gallagher, Treasurer, Dane County, Wisconsin

REGISTER OF DEEDS CERTIFICATE

Received for recording this _____ day of _____, 2018
at _____ and recorded in Volume _____ of Plats on Pages _____
as Document Number _____.

Kristi Chelbowski, Dane County Register of Deeds